

TECHNICAL DATA

Working Height	10 m
Platform Height	8 m
Horizontal outreach	3 m
Lift capacity	200 kg
Platform size	0.7 x 0,99 m
D - Length	2.65 m
B - Width	1 m
A - Height - stowed	1.99 m
Tailswing	0 cm
C - Wheelbase	1.2 m
E - Ground Clearance	10 cm
Driveable at full height up to	8 m
Drive speed proportional	0.7 - 4.5 km/h
Turning radius - outside	1.88 m
Turntable rotation	345°
Vertical jib rotation	130° (+70/-60)
Tires - non marking	16x5x10.5
Tilt alarm	3°
Gradeability	23 %
Hydraulic system capacity	7 l
Power source	24 V - 240 Amph
Weight	2760 kg

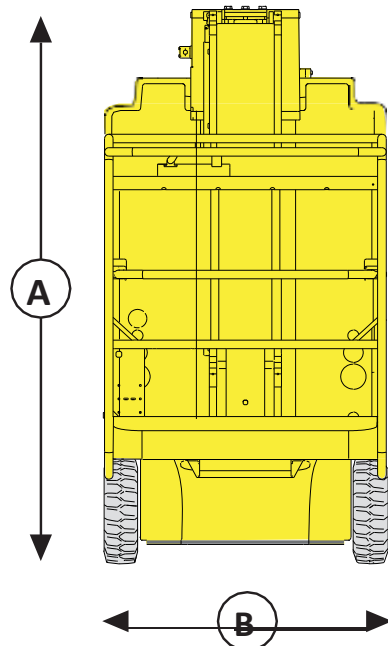

STANDARD FEATURES

- 24 V Electric motor
- 24 V – 240 Ah traction batteries
- 30 Amp battery charger
- Battery charge indicator
- Fixed potholes
- 2 drive speed
- 2 front steering wheels
- 2 back driving wheels
- Non-marking tires
- Brake release
- Hourmeter
- Horn
- Emergency stop buttons at cage and ground level
- Load controller in the platform
- Emergency hand pump
- 2 control stations at cage and ground level
- Fixed control station in the platform
- 2 rings in the platform for safety harnesses
- Towing hooks and lifting eyes

